



Board Level CNC Control for 3rd Party Servo Drives

Motion Controller, Drive Interface, and PLC (MPU11 & GPIO4D)

Starting at **\$2345** with CENTROID Mill or Lathe software

Machines in Motion, Inc.
 (714) 528-7061
 www.machinesinmotion.com
 sales@machinesinmotion.com

CNC PC choices:

Your Windows 7 PC



OR:
 Our All-in-One PC
 \$1175 (11084tb)



Ethernet
 Cable to PC

OR:
 Our CNC PC \$1175
 cabinet mount (#11084)
 & your display



OR:
 Our CNC console
 \$3225 (#11082)
 Panel Mount console \$2715 (#11170)
 Touch screen option \$495 (#12568)
 High perf PC upgrade \$615 (12858)



Standard Kit Includes:
MPU11 & GPIO4D
\$2345
 with CENTROID Software
 (#11022)

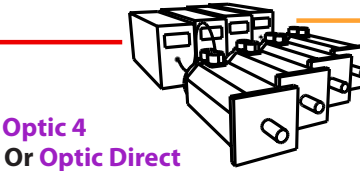
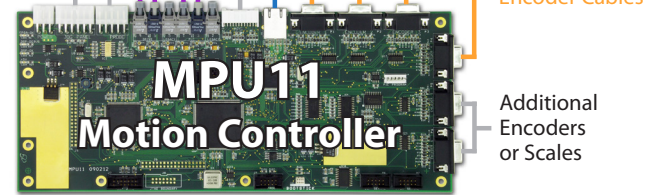
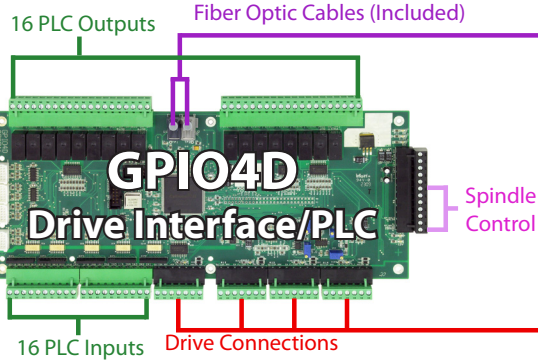

Yaskawa, Delta, Glentek, Sanyo
 Denki, Panasonic, Maxsine, and
 more... up to 4 axes standard

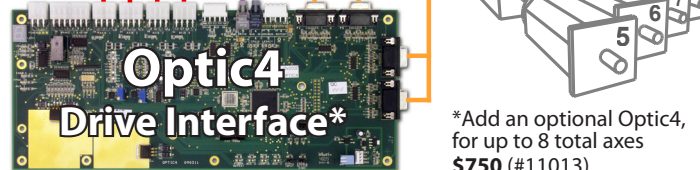

*Add an optional Optic4,
 for up to 8 total axes
\$750 (#11013)



Optional
 Operator's
 Control Panel
\$745 (#11077)



Optional
 Manual Pulse
 Generator (MPG)
\$495 (#11069)

Optional Touch Probe & Software
DP-4 \$1590 (#10405)
DP-7 \$4200 (#12431)

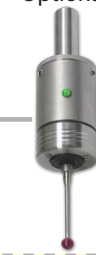

Optional
 Auto Tool Set
 - **TT-2 \$1310** (#12486)
 - **TT-1 \$725** (#10220)

Console, Display, & Cabinet opt. mounting hardware

- Console ext. cable in conduit (6 ft) **\$380** (#11028)
- Console cable in conduit (over 6ft) **\$28.50/ft** (#11028)
- Console mounting arm **\$299** (#10636)
- Console swivel mount (use w/ your arm) **\$135** (#10834)
- Rolling cabinet stand and display tray **\$595** (#10512)
- Rolling console stand **\$760** (#10695)
- Display/keyboard tray with arm **\$460** (#10240)
- Operators Pendant mounting hardware **\$76** (#10491)
- Internal MPG cable 20' w/bulkhead con. **\$110** (#11086)
- Internal Probe cable 6' w/bulkhead con. **\$50** (#11085)

Optional IO Expansion Boards
 Add up to 4 in any combination for up to 272 In / 272Out

PLC Add 1616
 16 Inputs (5, 12, 24 VDC)
 16 Relay Outputs
\$395 (#11025)

Add4AD4DA
 4 Digital to Analog Outputs
 4 Analog to Digital Inputs
\$525 (#11141)

PLC Add 6464
 64 Inputs 5V non isolated
 64 Outputs Open Collector
\$1290 (#11212)

Machines in Motion, Inc. 714 528-7061 sales@cncmachinesinmotion.com <http://cncmachinesinmotion.com>

The GPIO4d board set includes a separate motion control card "MPU11".

The GPIO4d card has 9 relay outputs and 16 inputs

The DC voltage used for inputs can vary from 5VDC, 12VDC, 24VDC. These inputs are grouped in groups of 4 so you can vary the voltage or change the common polarity for 4 inputs at a time.

Need additional I.O. ? There are plug in boards to provide as much as you require.

Servo control is formatted in Velocity mode. +-10VDC analog signal and required an encoder feedback. As long as your servo drive can be configured to this specification this board will be compatible.

The standard PLC programming that comes with your CNC software has the following features already configured.

4 axis of servo motion

VFD programmable spindle speed control

Spindle encoder input

Autolube pump and float sensor

flood and mist coolant

Monitors + & - axis limit inputs

Many other PLC configurations exist. If you require something special for your machine, just ask.